

USER'S MANUAL FOR

F & Q

Submersible Sewage Pumps

100WQ Series

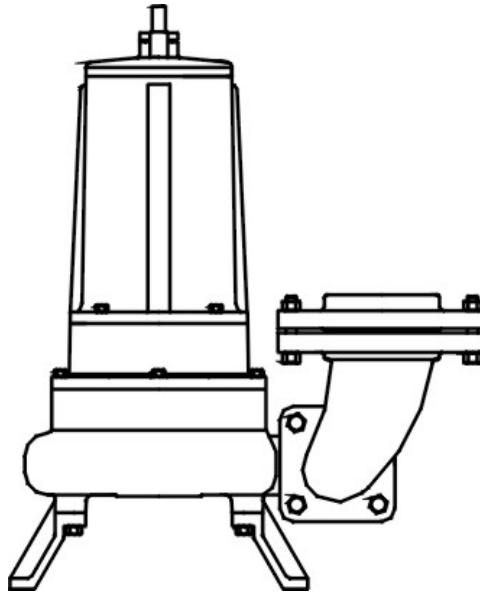

The F&Q pumps are carefully inspected and tested to ensure operating performance and safety. However, failure to follow the instructions and cautions in this manual can lead to pump damage or serious injury. Should questions arise, or start up problems occur, contact your pump distributor or the F&Q factory.

This manual must be read and understood before installation and maintenance. All installation, operation and maintenance works must be carried out by qualified personnel in strict accordance with this manual and must comply with all local, state, and national codes. F&Q Pumps, Inc. shall not be liable for injury, damage or delays caused by a failure to observe the instructions contained in this manual.

This submersible sewage pump is designed for installation in small lift stations, drainage systems or raw water applications and other light through heavy-duty wastewater services that require solids handling capability to 3” in diameter.

SPECIFICATIONS

Power supply required 208~230/460V, 60Hz, Three Phase
 Motor duty Continuous
 Temperature 104° F (40°C)
 Discharge 4” NPT
 Solids Handling 3”

PERFORMANCE

Model	V	Amps.	HP	GPM at head (ft)										Shut Off (ft)	Cord (ft)
				5	10	15	20	25	30	35	40	45	50		
100WQ1.5-4P	208~230/460	6/3	2	352	300	240	180	110	60					32	33
100WQ2.2-4P	208~230/460	9.6/4.8	3	395	355	325	285	215	180	115	25	12		46	33
100WQ3.7-4P	208~230/460	13/6.5	5	520	380	340	300	260	240	190	175	75	10	51	33

CENERAL SAFETY INFORMATION

1. Know the pump application, limitation, and potential hazards.
2. Disconnect power before attempting to service the pump.
3. Release all pressure within system before servicing any component.
4. Drain all water from system before servicing.
5. Personal safely:
 - a. Wear safety glasses at all times when working with pumps.
 - b. Keep work area clean, uncluttered and properly lighted-replace all unused tools and equipment.
 - c. Keep visitors at a safe distance from work area.
 - d. Be sure it is connected only to a properly grounded grounding type receptacle.
6. All wiring should be performed by a qualified electrician.
7. Protect electrical cord from sharp objects, hot surfaces, oil, and chemicals.
8. Do not handle pump or pump motor with wet hands or when standing on wet or damp surface, or in water.
9. Do not lift the pump by the cord.

10. When wiring an electrically driven pump, follow all electrical and safety codes that apply. Refer to the following chart to select the wire size of an extension cord if needed:

AMP RATING	TOTAL EXTENSION CORD(S) LENGTH IN FEET								AWG
	25	50	75	100	125	150	175	200	
0-10.0	18	18	16	16	14	14	12	12	
10.1-13.0	16	16	14	14	14	12	12	12	
13.1-15.0	14	14	12	12	12	12	12	--	
15.1-18.0	14	12	12	12	12	12	--	--	

CAUTION

Inspect the pumps before putting them to work:

- a. Immediately upon receipt of the shipment, inspect and check with the packing list and report to the transportation company's local agent any damage or shortage. Inspect carton and wrapping before discarding. Parts or accessories may sometimes be wrapped individually and packed in the carton.
- b. Make sure there are no nicks or cuts on the cord.

WIRING THE SUBMERSIBLE MOTOR

It is important to wire the motors correctly so that the direction of rotation of the pumps is correct. If the motor can be connected temporarily before it is lowered into the sump, a visual check can be made on its side so that the impeller can be viewed from the suction end of the pump. The motor should be started momentarily and the rotation checked. If it is incorrect, interchange any two leads at the starter and the rotation will be correct. The pump can then be installed in the pit. If the pump and motor unit has already been installed in the pit, the rotation can be checked in any of the following ways:

- a. Feel the discharge pipe with the hand while the pump is running. The vibration will be substantial if the pump is running in the wrong direction.
- b. Check the amperage draw of the pump while operating. Then switch two leads at the starter and check the amperage again. The lower amperage draw will indicate the correct direction of rotation.
- c. The pump will have less capacity if rotating in the wrong direction. Check the time it takes to pump the pit down from a high point to a low point. Then switch two leads at the starter and check the time again, The connection that requires the least amount of time to pump the pit down is the correct one.

PIPING

All pipes should be supported independently of the pump to avoid putting undue strain on the pumping unit. A union should be installed in the pump discharge line close to the sump cover that the discharge pipe can be broken and the pump removed from the pit with the discharge pipe intact.

A check valve and a gate valve should also be installed in each pump discharge line to prevent flow backwards through pump when pump shuts off.

Discharge pipe size should be no smaller than the pump discharge connection size, and in cases of long runs, it should be one or two pipe sizes larger.

PITS AND BASINS

Sump pits or basins should be inspected regularly and the sediment cleaned out as often as required.

PUMP OPERATION

- a. Keep the work area clean, uncluttered and properly lighted and keep visitors at a distance from the work area. Do not attempt to move the pump before disconnecting it from the power supply.
- b. For a satisfactory pump performance, users are recommended to choose an appropriate head for the pump according to the real height, to which liquids will be pumped. Too high a head causes delivery to decrease; too low a head could overload the motor. Over the time, If a pump stops abruptly and resumes working after a few minutes, causes should be checked and solved.
- c. If abnormal sound or a sudden increased noise is heard from a pump in use, stop to check for causes.
- d. According to the specifications of the pumps, filtering equipment is to be provided to prevent the solids larger than allowed from entering the pumps.
- e. Provide sufficient cooling to the pumps should they work in shallow water area where the motors may be seen out of water for a long time. This may get the motors burnt down due to over temperature increase.

TROUBLE SHOOTING CHART

Check the chart from time to time. It may offer you the solution(s) to the trouble(s) during operation and maintenance thus saving your time and unnecessary expenses.

Symptom	Possible Causes	Possible Remedies
Pump operates but delivers little or no water	<ol style="list-style-type: none"> 1. Debris caught in impeller, discharge 2. Water level too low, pump reaches out of water 3. Motor does not run or does not run at full speed 4. Rotates in a wrong direction 5. Impeller clogged or worn 	<ol style="list-style-type: none"> 1. Remove, clean and check for tightness 2. Adjust pump to a new position 3. Check the voltage of the power, the position of the starter switch 4. Interchange two leads at the starter 5. Clean the debris or replace the impeller
Motor unit overheats	<ol style="list-style-type: none"> 1. Too low line voltage 2. Wiring size too small 3. Work under low head, large volume conditions 4. Shaft worn out or clogged 5. Seal broken or leaking 	<ol style="list-style-type: none"> 1. Check the voltage or contact power company 2. Replace it as per the AWG chart provided 3. Adjust to rated head 4. Replace or mobilize it 5. Replace the seal and dry the motor
Pump operates noisily or vibrates excessively	<ol style="list-style-type: none"> 1. Shaft bent 2. Bearing worn 3. Joint bolt loose 	<ol style="list-style-type: none"> 1. Straighten the shaft 2. Replace the bearing 3. Tighten the bolt
Pump draws too much amperage	<ol style="list-style-type: none"> 1. Pump operates at lower head than that specified 2. Motor operates with less than the required voltage 3. Wrong direction of rotation 	<ol style="list-style-type: none"> 1. Adjust the pump to its specified head 2. Check the voltage or contact power company 3. Interchange two leads at the starter

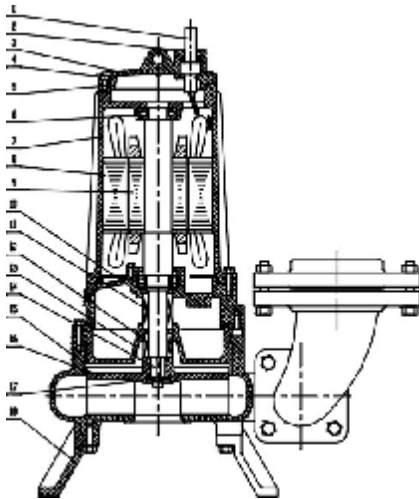

PARTS LIST			
1	Cord	10	Bearing Plate
2	Cord Grip	11	Dual Mechanical Seals
3	Pump Cover	12	Mechanical Seal
4	Cap screw	13	Seal Plate
5	O-Ring	14	Key
6	Bearing	15	Volute Casing
7	Motor Housing	16	Impeller
8	Stator	17	Washer
9	Rotor	18	Stand Leg

Limited Warranty

F&Q PUMPS, INC. hereby warrants your unit. In accordance with and subject to the provisions herein contained, against defects in material and workmanship under normal use and service when properly connected for a period of 12 months or 1000 hours operation (which ever occurs first), from the date of purchase. In the event of a breakdown or failure of your unit or part thereof, within the period of 12 months or 1000 hours operation, which prevents normal working, the Company will, if your unit is returned to the company or by permission to its agent, repair the breakdown or failure and replace any defective part or the whole unit at the Company's option free of charge. Freight charges will be the User's responsibility. Spare parts are normally stocked for a period of five years and generally stocked for the life of the unit.

This warranty does not extend to or cover the unit or any part of it which, in the opinion of the Company, has worn by reasonable wear and tear, abraded or corroded by fluid pumped, run in a dry condition, operated at high temperatures or outside the technical specification of the unit. Nor does warranty extend to cover the unit or any part of it which has been damage or rendered defective by accident, willful act, negligence (other than that by the Company), usage of other than the Company's parts, operation on voltages or frequencies other than indicated on the rating plate, incorrectly set voltage regulator, electrical fusion, lightning or by other major forces. This warranty is an exclusive warranty and is in lieu of all other warranties and conditions, expressed or implied, whether statutory or otherwise.

The Company shall not be liable for any loss or damage of any kind whatsoever (including injury or death to persons or animals or loss or damage to property) whether suffered or incurred by the user or by some third party where such loss or damage arises in relation to or as a result of the unit or any part thereof, and whether arising wholly or partly as a result of negligence of the Company, its agents or otherwise. Without limitation upon the provisions of the foregoing provisions of this clause, the Company shall not be liable for any consequential loss or damage (including financial loss or damage) and in no event and in not circumstances shall the liability of the Company to the user or any third party exceed the total purchase price of the unit or parts thereof in question.

Some states and countries do not allow limitations on how long an implied warranty lasts or the exclusion or limitation of incidental or consequential damages, so the above limitations or exclusions may not apply to you. This warranty gives you specific legal rights and you may also have other rights which vary from state to state and country to country.